



furnishing excellence™



 [www.friant.com/storage](http://www.friant.com/storage)

Our welded all-steel construction storage units offer aesthetic and structural integrity, and meet or exceed ANSI-BIFMA standards for durability and safety

Choose from lateral or pedestal files in multiple sizes, either supporting or mobile



- Drawer fronts radiused with recessed pulls
- Steel ball bearing full extension suspension drawers
- Safety Interlocking System ensures only one drawer will open at a time
- Master keyed, core removeable lock in black finish (Keyed alike option on request)



### Pedestal

#### Features:

- 19-22 gauge welded steel frame construction
- Load capacity 99 lbs (45 kg)

#### Options:

- Supporting or mobile
- 2 box drawer, 1 file drawer (BBF)
- 1 box drawer, 1 file drawer (BF)\*
- 2 file drawers (FF)

#### Dimensions:

- **Depth:** 19 <sup>9</sup>/<sub>16</sub> "
- **Width:** 14 <sup>3</sup>/<sub>4</sub> "
- **Heights:** BFF: 27 <sup>1</sup>/<sub>2</sub> "
- BF: 20 <sup>1</sup>/<sub>2</sub> "
- FF: 27 <sup>1</sup>/<sub>2</sub> "

#### Notes:

Mobile pedestals are shipped with counterweight installed. Pedestals are shipped with pencil tray and 1 box drawer divider.

\*BF is only available on XLT (6-8 week lead time)  
See System 2 price book for details



### Lateral

#### Features:

- 17-22 gauge welded steel frame construction
- Load capacity 242 lbs (110 kg)

#### Options:

- Supporting or mobile
- 2 box drawer, 1 file drawer (BBF)
- 1 box drawer, 1 file drawer (BF)
- 2 file drawers (FF)

#### Dimensions:

- **Depth:** 19 <sup>9</sup>/<sub>16</sub> "
- **Width:** 30, 36 or 42
- **Heights:** 2 Drawers high: 27 <sup>5</sup>/<sub>16</sub> "
- 3 Drawers high: 39 <sup>5</sup>/<sub>16</sub> "
- 4 Drawers high: 51 <sup>5</sup>/<sub>16</sub> "

— ALSO AVAILABLE —  
3 Styles of Paper Tray

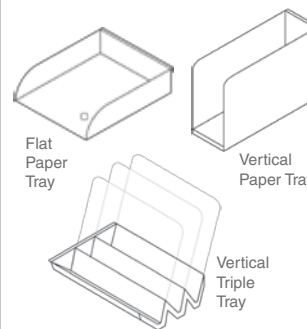

Flat Paper Tray

Vertical Paper Tray

Vertical Triple Tray

[www.friant.com](http://www.friant.com)